

**DYNAMIC SPEAKER**

Product No. 120214

BLS1635-11-08H06W25 LF

Issue no. BS/TES01.2022

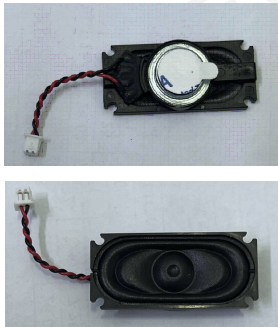

**Features:**

- Loud sound output
- RoHS

Drawn by	Checked by	Approved by	
Judy.Yang	Emma.Ren	Jason.Zhang	

BESTAR Holdings Co., Ltd.

www.be-star.com | info@be-star.com

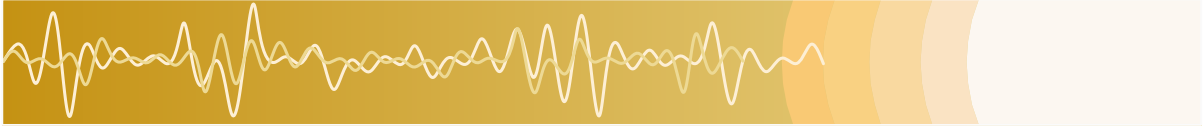

## Content:

1 Characteristics .....	3
1.1 Technical terms .....	3
1.2 Test method .....	3
1.3 Frequency Response Curve .....	5
2 Dimension .....	6
3 Reliability Test .....	7
4 Packing .....	8
4.1 packing drawing .....	8
4.2 Packing quantity .....	8
5 History change record .....	9
6 Important Notice .....	10



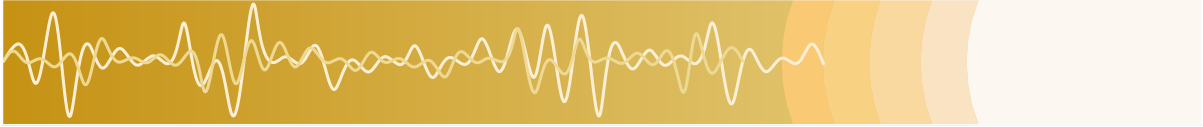

## 1.Characteristics

### 1.1Technical terms

1. Size	16*35*6.0mm
2. Impedance at 2KHz	8±15%Ω
3. Lowest Resonance frequency	700±20%Hz
4. Rated input power	1.0W
5. Maximum input power	2.0W
6. Buzz & Rattle(at sine wave 2.83V)	must be normal between 300-3500Hz
7. SPL	89±3dB (at 0.8K 1.0K 1.2K 1.5KHz in 0.1W/0.1m average (0dB SPL=20μPa))
8. THD	≤10% (at 1KHz/0.1W/10cm)
9. Operating temperature	-20...+60°C
10. Storage temperature	-30...+70°C



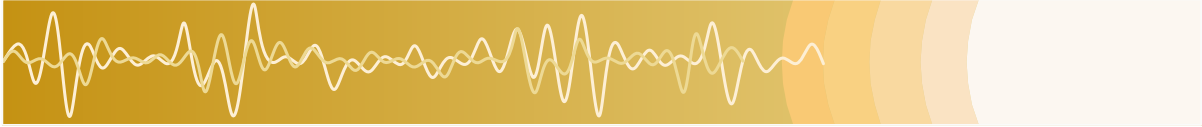

## 1.2 Test method:

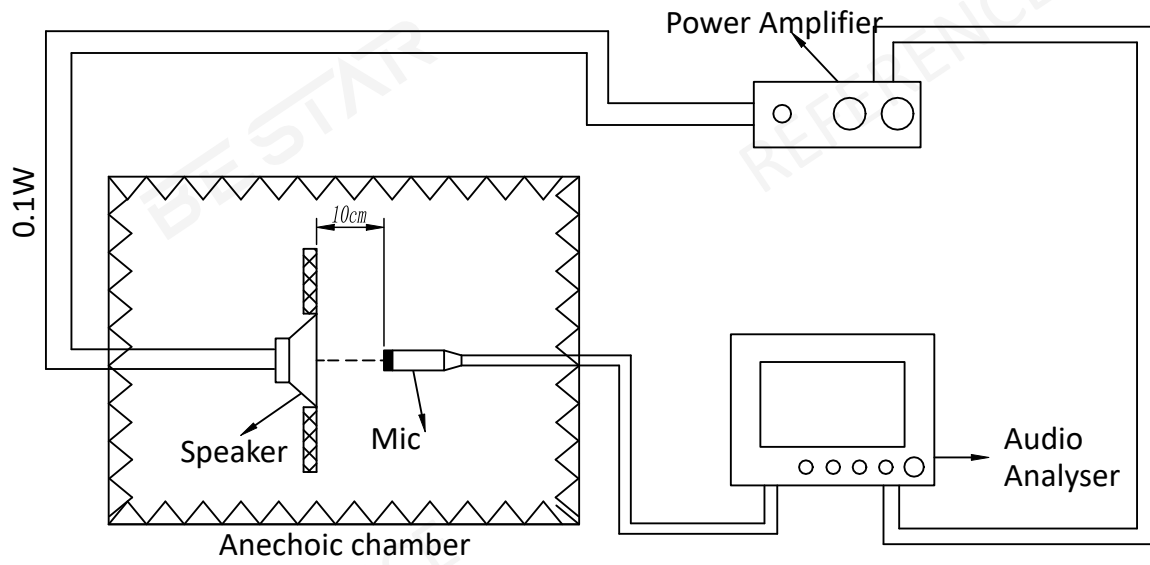



### 1.3 Frequency Response Curve (only for reference)

A: Frequency Response Magn 0 dB re 20.00  $\mu\text{Pa}/\text{V}$  1/12Oct



#### 1.3.1 Sensitivity

SPL is expressed in dB rel 20  $\mu\text{Pa}$ , computed according to IEC 268-5.  
Measurement set up according chapter 1.2 and parameters according chapter 1.3



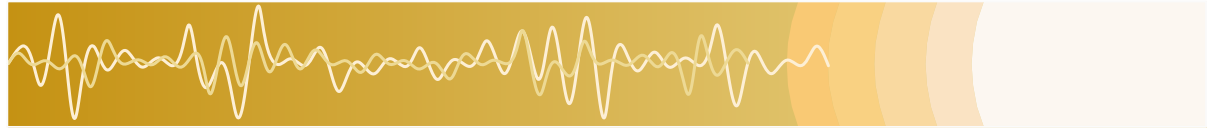

## 2. Dimension

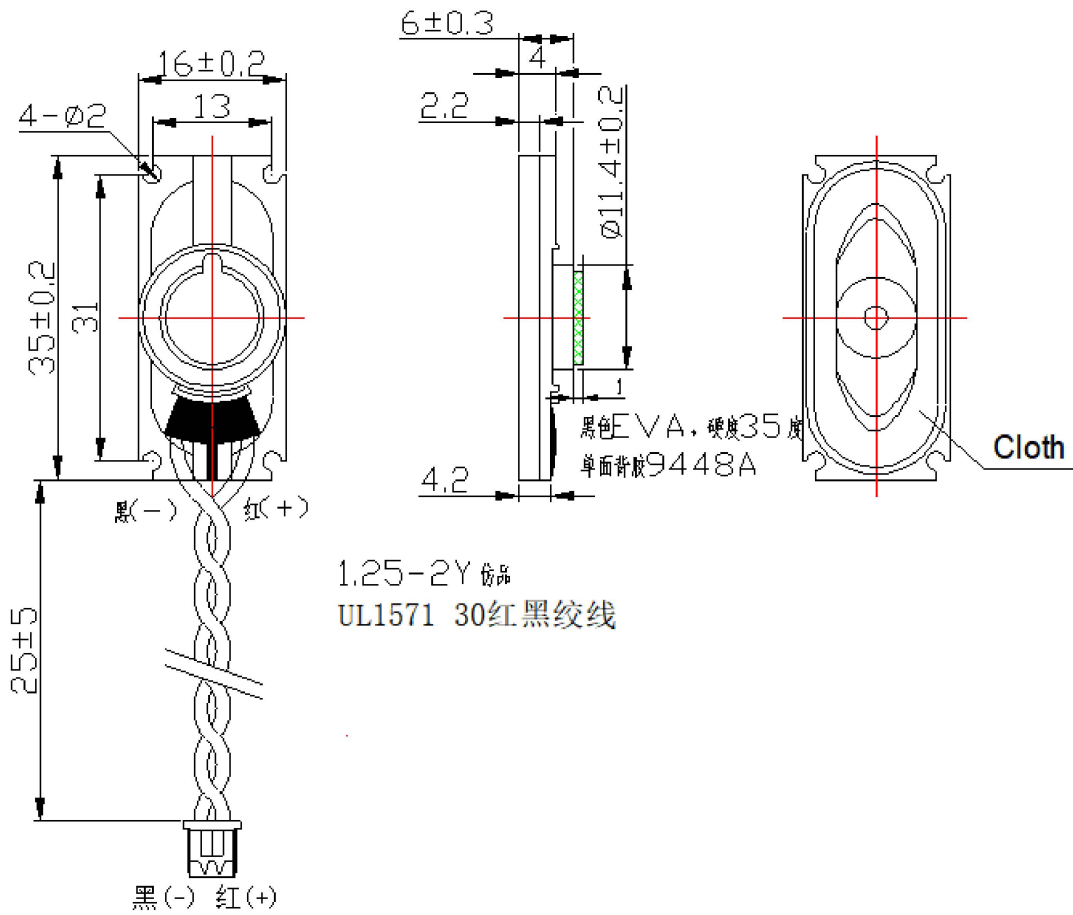

Tolerance:  $\pm 0.5\text{mm}$



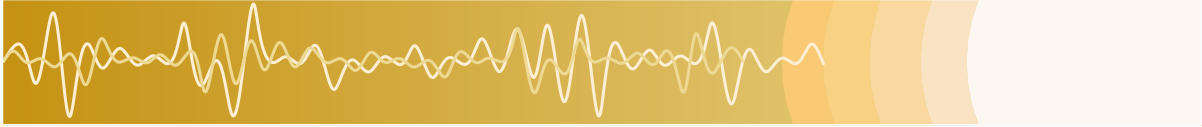

### 3. Reliability test

#### 3.1 High temperature preservation test

Temperature +70 °C  
Duration 96hrs

#### 3.2 Low temperature preservation test

Temperature -30 °C  
Duration 96hrs

#### 3.3 Humidity Test

Temperature +30±3 °C  
Relative Humidity 92%-95%RH  
Duration 96hrs

#### 3.4 Thermal Humidity Cycling

The part shall be subjected 5 cycles.

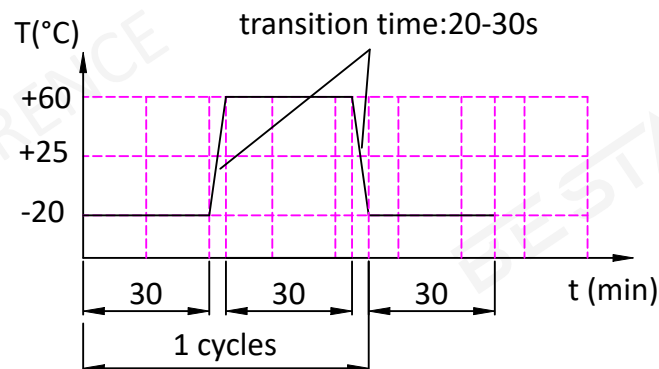

#### 3.5 Drop test

Drop the speaker contained in normal box onto the surface of 40mm thick board 10 times from the height of 75cm.

#### 3.6 Operation Life Test

Must perform normal with program White-Noise source at Rated Power for 96 Hours.



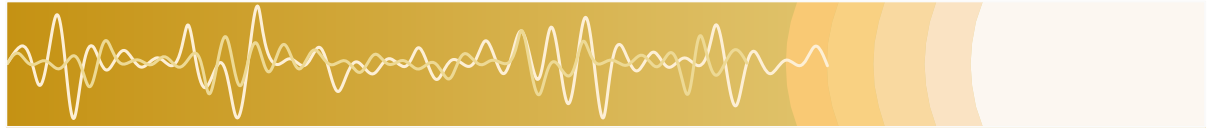

## 4. Packing

### 4.1 Packing drawing (unit:mm)

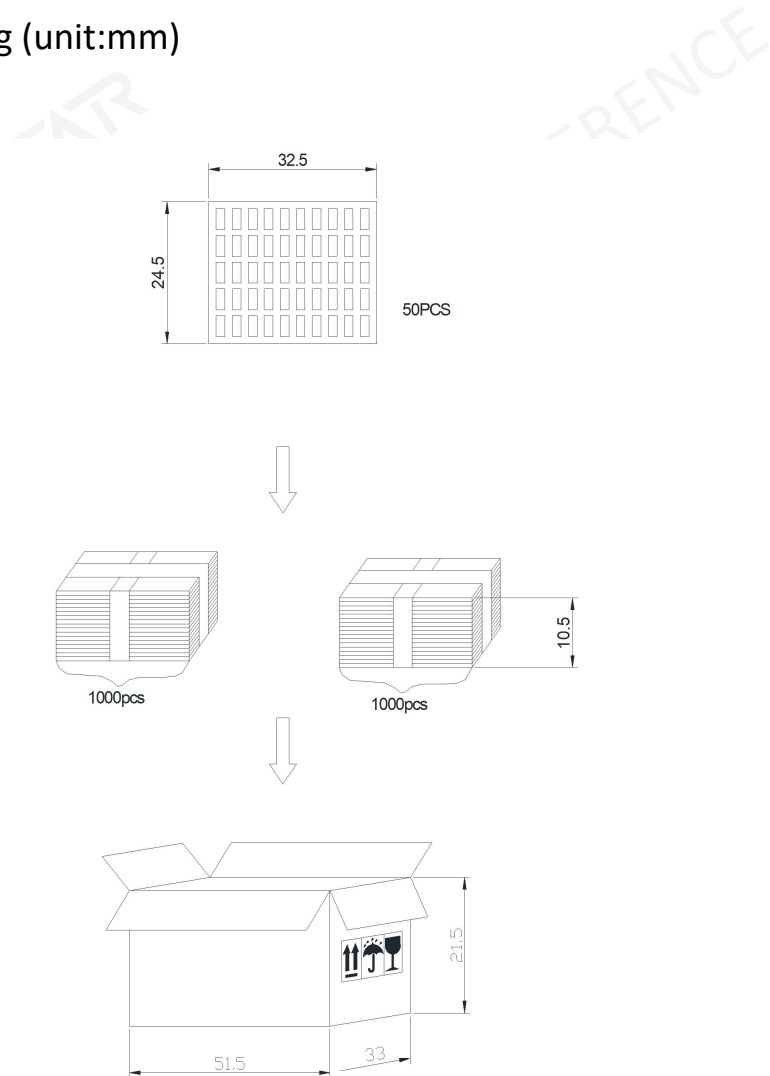

### 4.2 Packing quantity

- 1) 50pcs per tray
- 2) 40 trays per carton
- 3) 2000pcs per carton
- 4) carton size: 515X330X215mm





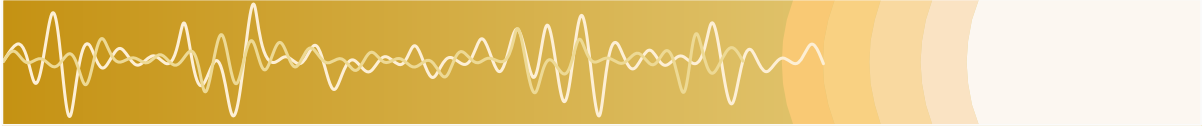

## 5. History change record

Version	Change Items	Date	Drawn	Checked	Approved
A0	First Edition	2022.02.11	Judy.Yang	Emma.Ren	Jason.Zhang

REFERENCE

BESTAR

BESTAR

REFERENCE



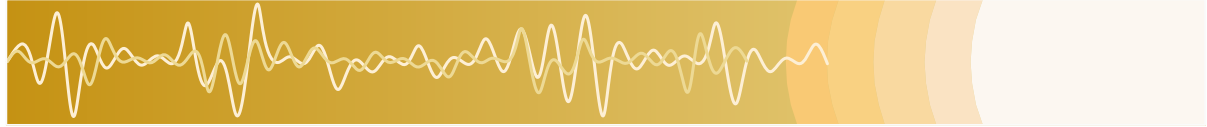

## 6. Important Notice

### 6.1 The products mustn't be washed

### 6.2 Storage Condition (Packaging)

The products should be stored in the room, where the temperature/humidity is stable. And avoid such places where there are large temperature changes. Please store the products at the following conditions:

Temperature: -10 to + 40 °C Humidity: 15 to 85% R.H.

### 6.3 Expire Date on Storage

Expire date (Shelf life) of the products is six months after delivered under the conditions of a sealed and an unopened package. Please use the products within six months after delivered.

If you store the products for a long time (more than six months), use carefully because the products may be degraded in the solderability and/or rusty. Please confirm solderability and characteristics for the products regularly.

### 6.4 Notice on Product Storage

(1) Please do not store the products in a chemical atmosphere (Acids, Alkali, Bases, Organic gas, Sulfides and so on), because the characteristics may be reduced at quality, and/or be degraded in the solderability due to the storage in a chemical atmosphere.

(2) Please use the products immediately after the package is opened, because the characteristics may be reduced at quality, and/or be degraded in the solderability due to storage under the poor condition.

### 6.5 Rated and Max input power

Rated input power

Rated input power is the maximum (limit) value which can be input to the component intentionally. If the actual input power to component keeps exceeding Rated Input power, it will damage the component acoustic performances and reliability. In the worst case, the component will get broken and no sound.

Max input power

Max input power is the maximum (limit) value for unexpected input power which is caused in the customer's circuit like surge voltage. If the actual input power to component keeps exceeding Maximum input power, it will break the component and cause no sound in a short time. Please note that component will have a risk to get broken if the unexpected input power continues.

The value of input power is set based on the sinusoidal power in the normal speaker use. If the special signal is input to component, the values of Rated and Max input power will be different. Please make a well-investigation at your laboratory in the case of the special signal input.

