

Magnetic Vibrator

Product No. 210835

BMV3520H12

Issue No. BS/TEV01.52

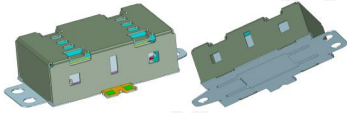

Features:

- External driving circuit
- Screen vibration
- Heavy acceleration
- RoHS

Drawn by	Checked by	Approved by	Customer approved
Fay.Chen	Hansen.Tao	Richard.Cheng	

BESTAR Holdings Co., Ltd.

www.be-star.com | info@be-star.com



Content:

1 Characteristics	3
1.1 Technical Terms	3
1.2 Environmental Conditions	3
1.3 Haptic actuator Measurement Circuit	4
1.4 Acceleration Characteristics	5
2 Drawing.....	6
2.1 Product Dimensions	6
2.2 Exploded View	7
3 Reliability Test	8
4 Environment Performance Test	8-9
5 Packing quantity.....	10
6 History Change Record	11
7 Important Notice	12





1.Characteristics

1.1 Technical Terms

1. Resistance	6.5Ω±25%@20°C
2. Rated voltage	2.5Vrms
3. Operating voltage	0.3~2.83Vrms
4. Resonance Frequency	120±20%Hz
5.Acceleration	≥6Grms, 100g load in middle, 2.5Vrms
6.Weight	≈27g
7.*RT(Rise Time) 0→90%	≤100ms
8. *BT(Break Time) 100%→10%	≤150ms

*@ 100g load in middle,2.5Vrms,120Hz,10cm

1.2 Environmental Conditions

1. Standard conditions for inspection and measurement:

- (1) Temperature: +15...+35°C
- (2) Humidity: 45...85%RH (no condensation of moisture)

When a judgment under standard conditions raises doubt, the following conditions apply:

- (1) Temperature: +18...+22°C
- (2) Humidity: 50...60%RH (no condensation of moisture)

- 2. Operating Temperature: -40...+85°C
- 3. Storage Temperature: -40...+95°C





1.3 Haptic actuator Measurement Circuit

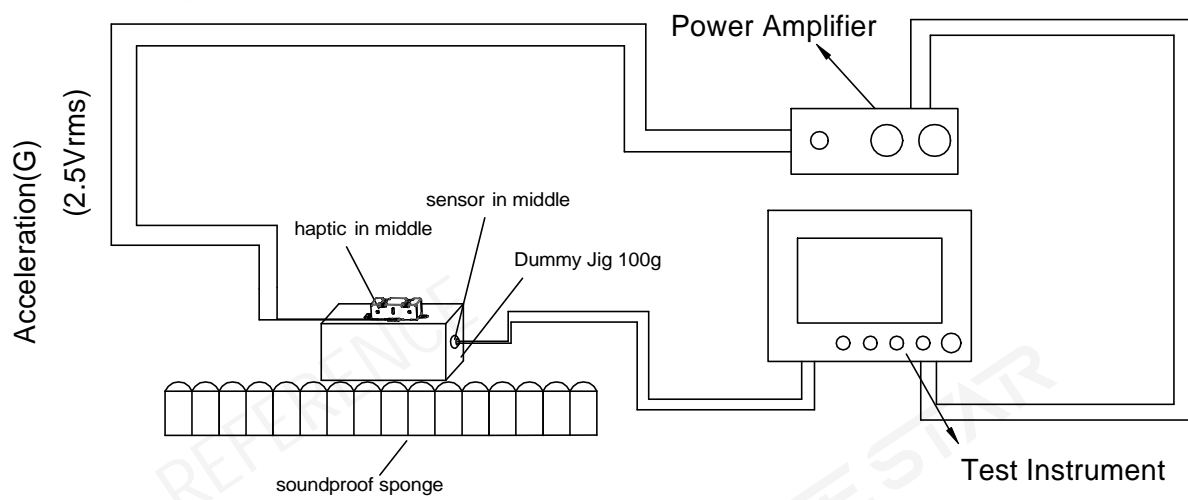

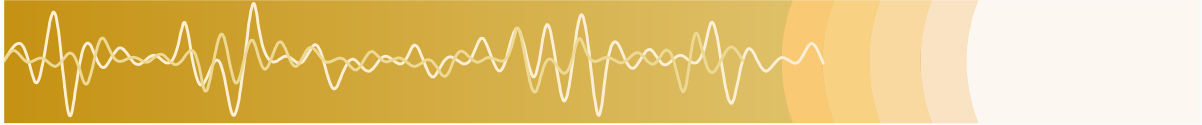

1.4 Acceleration Characteristics(only for reference)

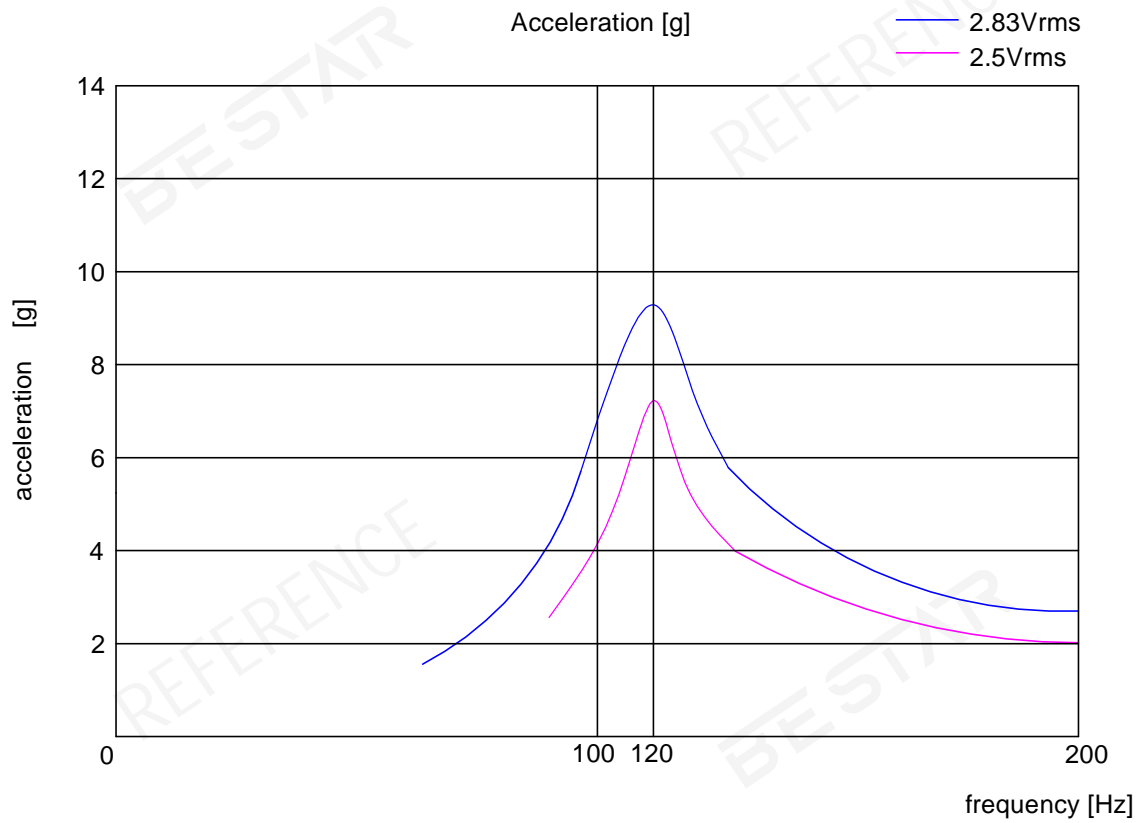

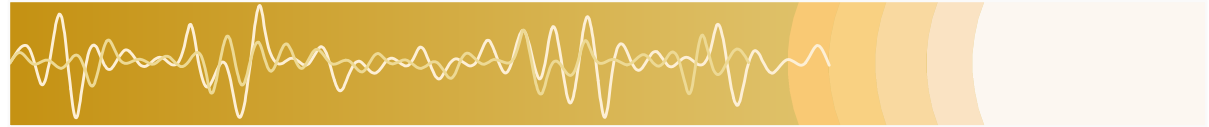

2. Drawing

2.1 Product Dimensions

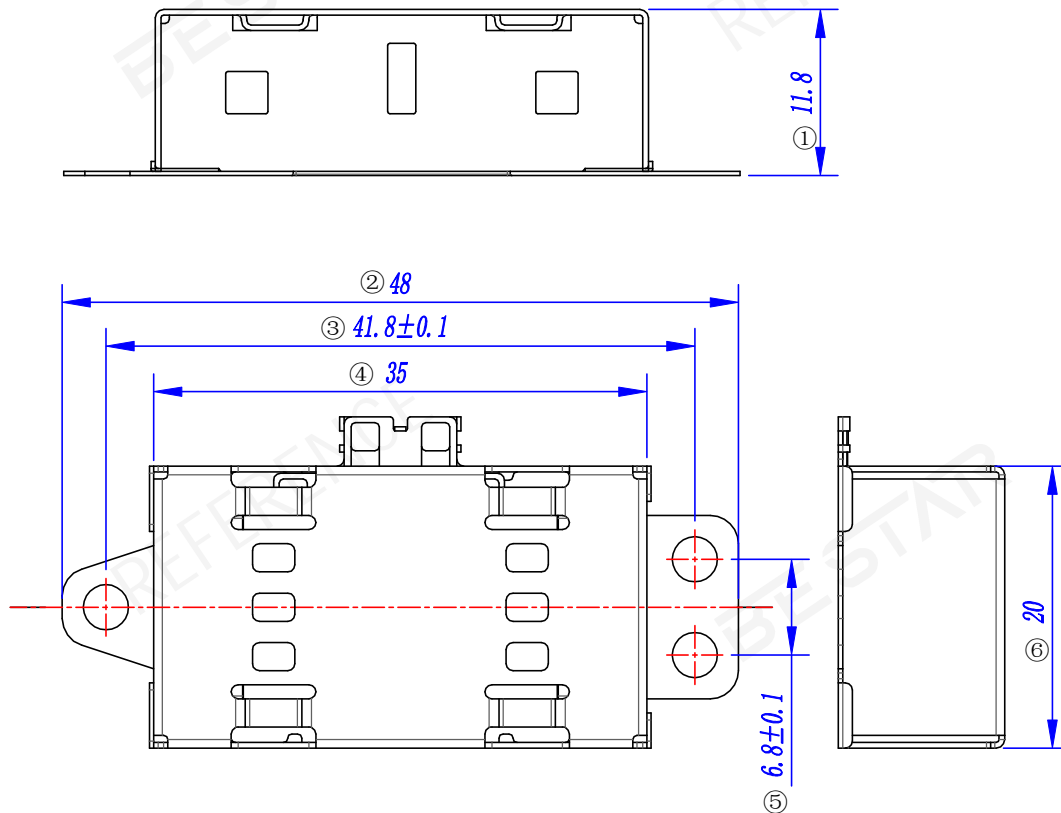

Unit:mm
Tolerance:±0.2



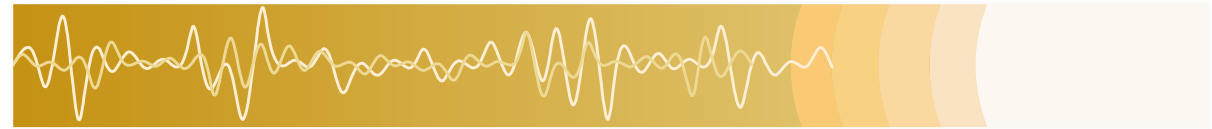

2.2 Exploded View

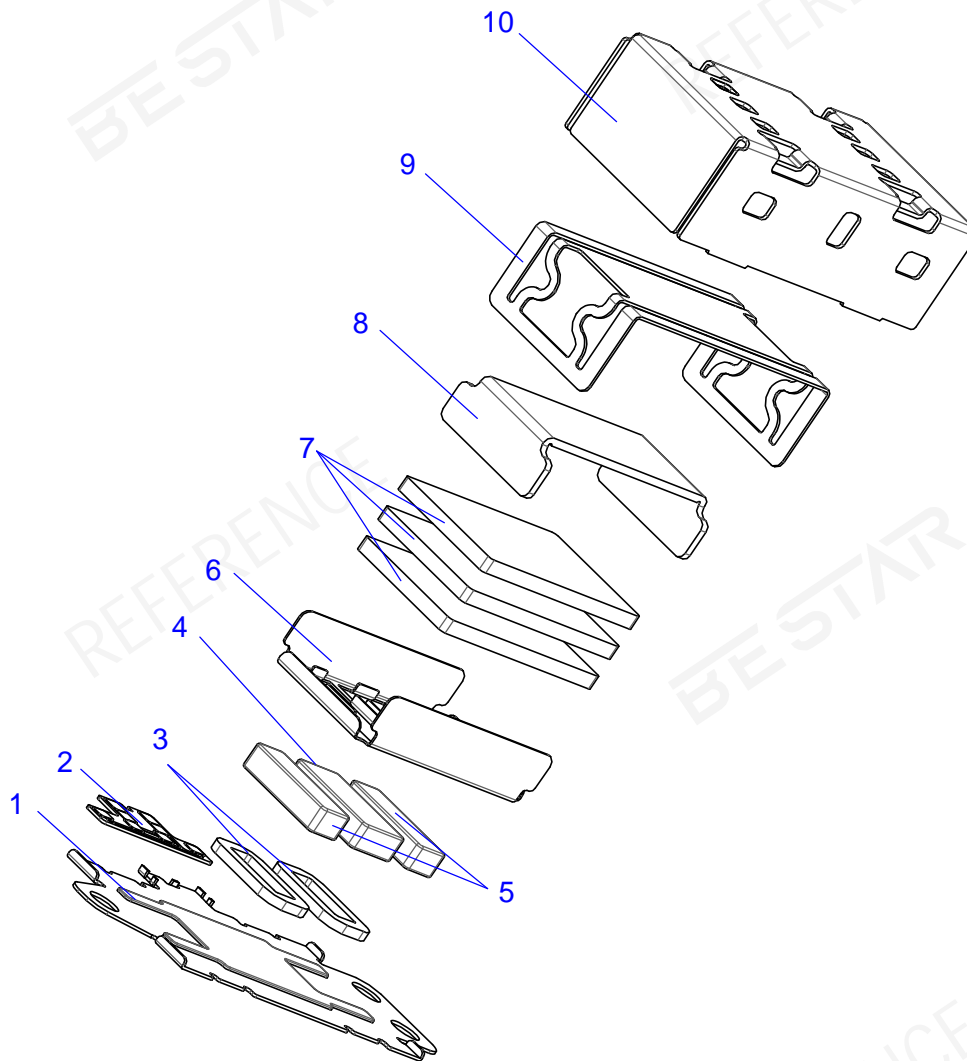

10. Metal Housing	SUS
9. Spring	SUS
8. Magnetic shield	SUS
7. Mass	SPCC
6. Metal frame	SUS
5. Sub magnet	NdFeB
4. Main magnet	NdFeB
3. Voice Coil	Φ0.1
2. PCBA	FR4
1. Base Plate	SUS



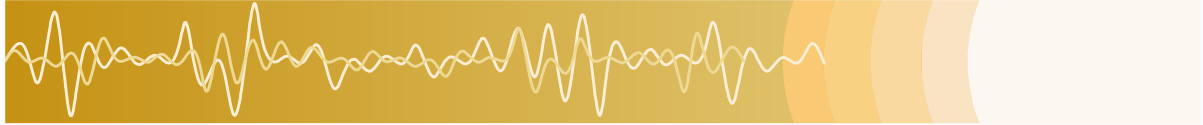

3. Reliability Test

3.1 Load test

Power (Nom)	2.5Vrms,30ms ON/470ms OFF
Input signal	120Hz sine wave
Duration	1000hrs

3.2 Drop test

Height	1m
(fix onto the 200G, 6000 series aluminum alloy carrier and drop on the 10mm thickness woodenboard)	
Direction	Once in each of the three directions

4. Environment Performance Test

4.1 High temperature storage test

Temperature	+95±2°C
Duration	1000hrs

4.2 Thermal shock test

Temperature	-40~+85°C
Duration	1000hrs

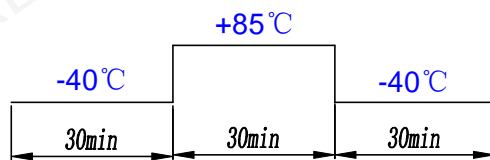

4.3 Damp Heat

Temperature	+85±2°C
Relative Humidity	85±2%RH
Duration	1000hrs

4.4 Low temperature storage test

Temperature	-40±2°C
Duration	500hrs

4.5 Temperature cycles Test

Cycles	80
--------	----

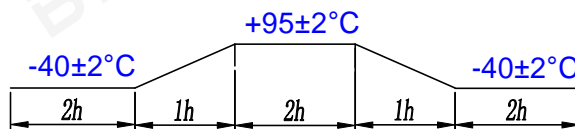



Performance requirements after test:

- 1) Acceleration: $\geq 5.5G$ @ 100g load in middle, 2.5Vrms
- 2) RT (Rise Time): $< 120ms$ @ 100g load in middle, 2.5Vrms, 120Hz
- 3) BT (Break Time): $< 180ms$ @ 100g load in middle, 2.5Vrms, 120Hz

Notice: Before the experiment, it should work normally for 1 hour; after the experiment, it should be placed at room temperature for at least 4 hours to test its performance.



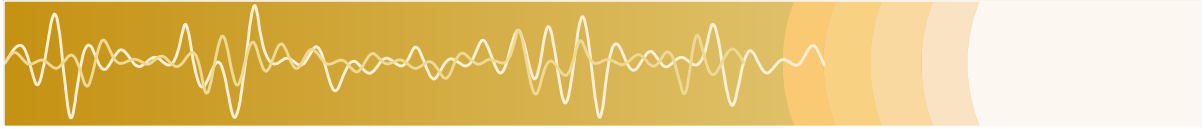

5.Packing quantity

TBD





6. History Change Record

Version	Change Items	Date	Drawn	Checked	Approved
A0	First Edition	2021.08.26	Fay.Chen	Hansen.Tao	Richard.Cheng

REFERENCE

BESTAR

BESTAR

REFERENCE



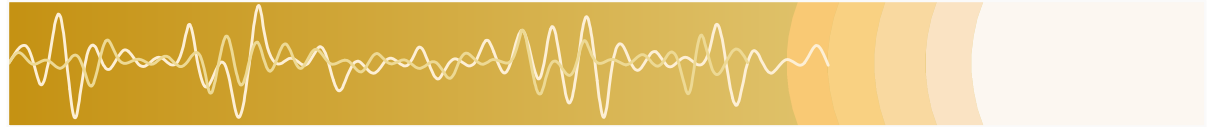

7. Important Notice

7.1 The products mustn't be washed

7.2 Structural and component changes

The structure and components of the product can be modified to improve the quality of the product without changing the size and performance requirements

7.3 Store Condition (packaging)

The products should be stored in the room, where the temperature/humidity is stable. And avoid such places where there are large temperature changes. Please store the products at the following conditions:

Temperature: -10 to +40°C Humidity: 15 to 85% R.H.

7.4 Expire Date on Storage

Expire date (Shelf life) of the products is six months after delivered under the conditions of a sealed and an unopened package. Please use the products within six months after delivered.

If you store the products for a long time (more than six months), use carefully because the products may be degraded in the solderability and/or rusty. Please confirm solderability and characteristics for the products regularly.

7.5 Notice on Product Storage

(1) Please do not store the products in a chemical atmosphere (Acids, Alkali, Bases, Organic gas, Sulfides and so on), because the characteristics may be reduced at quality, and/or be degraded in the solderability due to the storage in a chemical atmosphere.

(2) Please use the products immediately after the package is opened, because the characteristics may be reduced at quality, and/or be degraded in the solderability due to storage under the poor condition.

7.6 Rated and Max input voltage

Rated input voltage

Rated input voltage is the maximum (limit) value which can be input to the component intentionally. If the actual input voltage to component keeps exceeding Rated Input voltage, it will damage the component acoustic performances and reliability. In the worst case, the component will get broken and no sound.

Max input voltage

Max input voltage is the maximum (limit) value for unexpected input voltage which is caused in the customer's circuit like surge voltage. If the actual input voltage to component keeps exceeding Maximum input voltage, it will break the component and cause no sound in a short time. Please note that component will have a risk to get broken if the unexpected input voltage continues.

The value of input voltage is set based on the sinusoidal voltage in the normal speaker use. If the special signal is input to component, the values of Rated and Max input voltage will be different. Please make a well-investigation at your laboratory in the case of the special signal input.

